



CORP ILUMINAT INTERCONECTABIL LED mat 7W

CARACTERISTICI TEHNICE

- Tensiune: 240V
- Frecvență: 50Hz/60Hz
- Putere: 7W
- Factor de putere: > 0,5
- Tip LED: SMD mat
- Temperatură de culoare: 3000K / 4000K / 6500K
- Raport eficiență flux luminos: ≥70 Lm/W
- Indice redare culori: RA>80
- Clasă eficiență energetică: A+
- Grad protecție: IP20
- Durată de viață: 25000 ore
- Temperatură optimă de lucru: -10 °C ~ +40 °C
- Material carcasă: PC (polycarbonat)
- Tip: SBT5 cu întrerupător
- Lungime cablu: 15cm
- Tip conector: rigid
- Garanție: 2 ani

PARAMETRII TEHNICI

Cod Elvon	Denumire produs	Putere (W)	Temperatură de culoare (K)	Dimensiuni (mm)
20393	CORP ILUMINAT MAT LED SBT5 AL2016 584X27X32 3000K 7W	7	3000K	584 × 27 × 32
20394	CORP ILUMINAT MAT LED SBT5 AL2016 584X27X32 4000K 7W	7	4000K	584 × 27 × 32
20395	CORP ILUMINAT MAT LED SBT5 AL2016 584X27X32 6500K 7W	7	6500K	584 × 27 × 32



INSTRUCȚIUNI MONTAJ

Atenție! Opriti alimentarea electrică înainte de montare.



20294/5	LED 10W BT8	240V; 50Hz
20254/5	LED 7W BT5	240V; 50Hz
20394/5	LED 7W SBT5	240V; 50Hz
20354/5	LED 8W BT5	240V; 50Hz

1



2

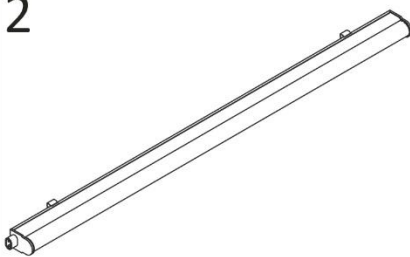

3

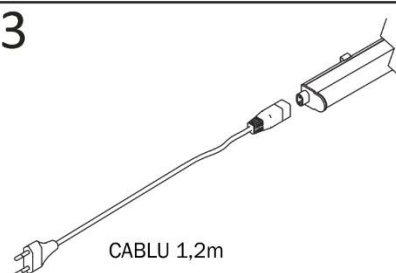

CONECTARE LINIARA

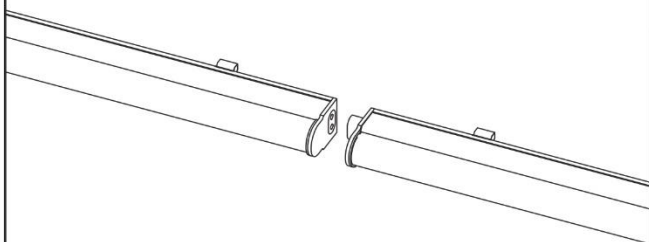

CONECTARE IN UNGHII

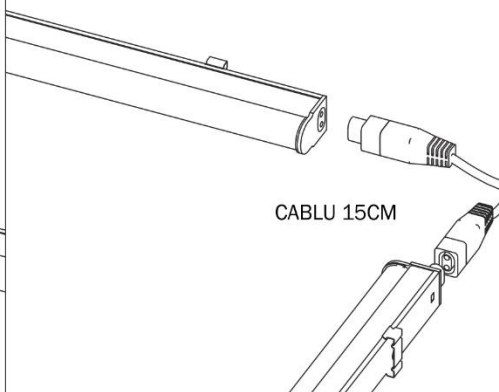

DIMENSIUNI (A × B × C) mm

20294/5	600 x 25 x 35
20254/5	535 x 21 x 34
20394/5	584 x 27 x 32
20354/5	580 x 23 x 33

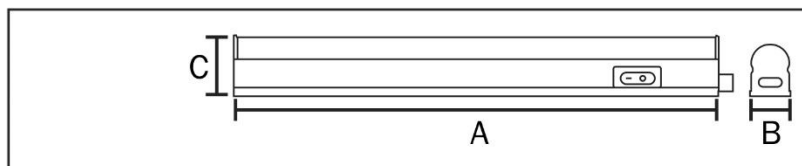

Distanța minimă față de material inflamabil, în direcția razei de lumină

LED

